



# FWH-25-30-40 TP2 HW HIGH SPIN

**G FORCE = 450** | 25 - 30 - 40 lb

MAXIMUM EFFECTIVENESS,  
ENERGY SAVING AND RESPECT FOR THE ENVIRONMENT



## CHARACTERISTICS

- G Force = 450.
- Drum and jacket in AISI-304 stainless steel.
- Unit exterior manufactured in sandwich board, colour grey, stainless steel appearance, easy to clean, and which does not reflect fingerprints.
- Detergent tray with 4 compartments.
- 8 signals for automatic liquid dosing, programmable in time and delay. 6 extra signals available optionally.
- 3 standard water inlets.
- Variable-frequency drive (standard 50-60 Hz). Balancing system controlled by the same drive.
- **New second-generation TOUCH PLUS programmer with 7" touch screen in colour**, 37 available languages and which lets you create an indefinite number of programs (29 pre-set), as well as play videos.
- Allows programming, importing and exporting of programs and software updates via USB.
- Traceability as standard: the whole wash process (temperatures, water levels) is stored on the washer and is extractable to a PC by USB memory.
- The programmer includes the characteristics to create any Wet Cleaning program (modifiable water levels and washing speed).
- **EFFICIENT MIX.** These machines are equipped with an automatic water mixer (mixing different water temperatures) which provides energy savings and reduces washing times.

- **BALANCE CONTROL.** Thanks to an advanced technological development, and by means of the inverter, the washers detect the imbalance at an early stage. This way the operation is much smoother, elongating components lifetime and reducing washing times, thus saving energy as well.
- **MULTI-CHOICE INLET.** All washers are equipped with a third water inlet as standard, which allows you to save filling time, or which can be used for decalcified water, ozone or recycled water.
- **WET CLEANING.** WET CLEANING. All washers incorporate the necessary features to use the WET CLEANING system as standard, avoiding investment in expensive applications to work with this advanced washing concept. This feature replaces most dry-cleaning washing systems, bringing maximum reduction in costs.
- **MAINTENANCE KARE.** A simple and reliable design with easy-to-access mechanical parts that combines perfectly with the use of intelligent electronics. All components have been designed and manufactured with top quality and prestige, focusing on optimum accessibility for all points and components key to maintenance. Moreover, all the controls have been developed down to the finest detail: complete technical menus, fault self-diagnosis systems, alarms, restricted access areas, etc.

- **OPTIMIZED DRUM.** This system has been developed to improve wash quality to the maximum and to do it in as short a time as possible. Through a series of perforations in the paddles of the machine, a water cascade effect is achieved which increases the mechanical action of the drum during operation and greatly reduces the amount of water needed for each wash. The effective design of the drum and tank with minimal spaces between them, allows the energy consumption necessary to heat the water, as well as the superfluous use of chemical products, to be reduced.
- **OPTIMAL CONSUMPTION.** All washers are equipped with an efficient system by means of which you can indicate the load which is introduced in the machine. The washer automatically adapts the quantity of water and chemicals to be used for that load.
- **"LOADING AID"** system. Water inlet and spin control for loading the linen.
- The standard model can be converted to self-service by installing a pay station kit, coin mechanism kit or other payment system. RS-485 communication.
- Washers compatible with water recovery tanks.
- **CE, WRAS and EAC product certifications.** Optional ETL-certified version of the machine.

### OPTIONS:

- Unit exterior in AISI-304 stainless steel.
- Front panels in AISI-304 stainless steel.
- Different levelling plinth kits to level machines by total height or by loading height (850 mm between door base and floor).
- Double drain kit to recover the water, with important savings.
- NC Option: drain normally closed.
- Drain pump kit (25 and 30 lb).
- Levelling feet.
- Reversible door opening.
- Silicone seal for 25 and 30 lb models.
- 6 extra signals for dosing.
- **AUTO WEIGHT** Automatic linen weighing system. Up to 30% savings. (Automatic adjustment of water and soap consumptions as well as energy savings, according to the load inserted, measured automatically by the washer).
- Timed opening system.
- Printer.
- Marine electric versions for ships.
- Tropicalised models with protective covering for the electronics system.
- **Shower system:** water recirculation for very delicate linen (wet cleaning complement).



TECHNICAL DATA

	UNIT.	FWH-25 TP2		FWH-30 TP2		FWH-40 TP2	
<b>DRUM</b>							
Load capacity 1:9 / 1:10	lb	24/22		31/29		44/42	
Volume	CU.FT	3.5		4.6		6	
Diameter	in	20.9		24.40		27.55	
Depth	in	16.73		16.92		18.50	
<b>GENERAL DATA</b>							
Wash speed / Spin speed	r.p.m.	50/ 1,231		50/ 1,138		47/ 1,071	
G Force	-	450		450		450	
Maximum force transmitted	kN	2.08 ±0.75		2.49 ±1.05		3.41 ±1.4	
Dynamic force frequency	Hz	16.7		16.7		16	
Noise level	dB	70		70		70	
Self-service version	-	Yes		Yes		Yes	
Double drain	-	No		Opt.		Opt.	
Weighing system	-	Opt.		Opt.		Opt.	
<b>DOOR</b>							
Height door centre / Height door base	in	24.8/14.56		700 / 440		765 / 450	
Diameter	in	14.68		14.68		18.11	
<b>POWER</b>							
Motor	Hp	1		2		2.9	
Heating electric mod.	Hp	8		12		16	
Maximum electrical power	Hp	8.4		12.6		17.1	
Maximum steam and hot water power	Hp	1		1.48		2.9	
<b>CONNECTIONS</b>							
		<b>ELECTRIC</b>	<b>STEAM / HOT WATER</b>	<b>ELECTRIC</b>	<b>STEAM / HOT WATER</b>	<b>ELECTRIC</b>	<b>STEAM / HOT WATER</b>
Voltage 230V - I + N	N° x mm² / A	3 x 4 / 32 A	3 x 1.5 / 6 A	3 x 10 / 50 A	3 x 1.5 / 10 A	3 x 16 / 63 A	3 x 1.5 / 10 A
Voltage 230V - III	N° x mm² / A	4 x 2.5 / 20 A	-	4 x 4 / 25 A	-	4 x 6 / 40 A	-
Voltage 400V - III + N	N° x mm² / A	5 x 1.5 / 10 A	-	5 x 1.5 / 16 A	-	5 x 2.5 / 20 A	-
Steam input (Steam mod.)	inch	1/2"		1/2"		1/2"	
Maximum steam consumption (Steam mod.)	kg/h	7		8.5		12	
Water inlet	inch	3/4"		3/4"		3/4"	
Grid pressure	kg/cm²	2-4		2-4		2-4	
Maximum water consumption *	Gal/h	18.86		23.45		31.25	
Drain	mm/inch	3"		3"		3"	
Drainage capacity	Lit/min	200		200		200	
<b>DIMENSIONS / DIMENSIONS WITH PACKAGING</b>							
Width / Width	in	27.24/28.74		31 / 32.67		34.80/ 36.61	
Depth / Depth	in	31 / 39.37		34.21 / 39.76		36 / 40.55	
Height / Height	in	46.65 / 55.78		51.46 / 61.42		55.70 / 66.93	
Net weight / Gross weight	lb	507 / 526		551 / 623		794 / 867	
Gross volume (with packaging)	m³	1.03		1.31		1.63	

\* Program n° 20, 75 % load.

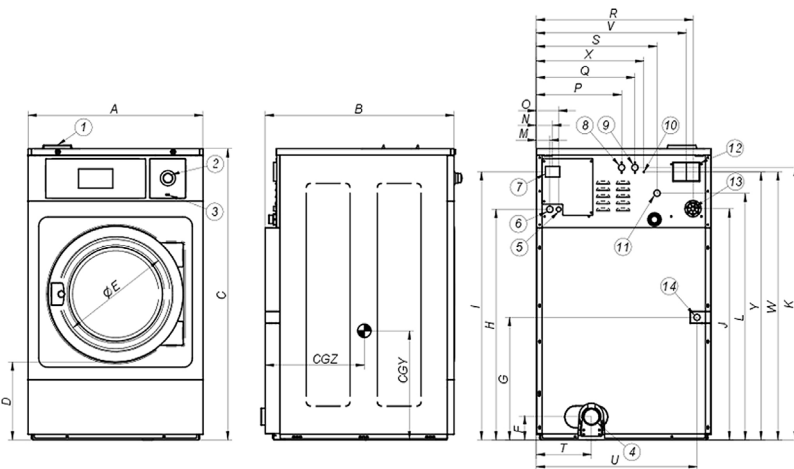

- ① Soap dispenser.
- ② Emergency stop.
- ③ USB port.
- ④ Drain.
- ⑤ Electrical connection to liquid soap pumps.
- ⑥ Electrical connection.
- ⑦ Main switch.
- ⑧ Auxiliary water inlet.
- ⑨ Hot water inlet.
- ⑩ Earth connection.
- ⑪ Cold water inlet.
- ⑫ Water overflow.
- ⑬ Connection for liquid soap.
- ⑭ Steam connection.

	A	B	C	D	E	F	G	H	I	J	K	L	M	N	O	P	Q	R	S	T	U	V	W	X	Y	CGZ	CGY
<b>FWH-25 TP2</b>	27,24	31,02	46,65	14,57	14,69	4,92	13,94	35,94	42,72	36,06	43,31	38,78	2,40	2,91	3,98	12,44	14,61	24,02	17,64	8,90	24,65	22,83	42,52	18,15	45,08	16,69	22,72
<b>FWH-30 TP2</b>	31,02	34,21	51,46	17,32	14,69	9,57	15,16	40,71	47,32	40,83	48,07	43,54	2,40	2,91	3,98	15,16	17,52	27,80	21,42	9,57	28,27	26,61	47,32	19,09	47,28	17,72	25,63
<b>FWH-40 TP2</b>	34,80	35,94	55,71	17,72	18,11	3,74	14,96	44,69	51,30	44,80	52,05	47,52	2,40	2,91	3,98	16,89	20,04	31,57	25,20	13,70	32,05	30,39	51,30	22,40	51,06	18,27	27,64