

60-lb Capacity Soft Mount/350 G-Force Coin Washer/Extractor

Features and Benefits:

- Coin or Card Ready
- Inverter Driven Motor
- Soft Mount
- Stainless Steel Cabinet
- Easy to Program and Easy to Use Controls
- Load Imbalance Detection Before Spinning
- Large, Convenient Supply Dispenser
- Flexible Water Level Settings
- Ergonomic, Easy-Grip Door Handle
- 10 Year Manufacturer's Warranty*

Why Purchase ADC EcoWash?



EWH-60 Coin Washer/Extractor

Soft Mount

EcoWash high spin washer/extractors feature a heavy-duty cast aluminum counter weight and our automatic imbalance detection system. Together these provide maximum stability and gentler movement, prolonging the unit's life.

Durable Door Safety Lock and Handle

The durable ergonomic design of the door handle combined with our Easy Lock™ door lock provides maximum convenience and safety.

Large, Convenient Supply Dispenser

Easy to use, this large supply dispenser allows you to conveniently load your detergent, bleach and fabric softeners before starting your wash cycle.

10 Year Manufacturer's Warranty

ADC's EcoWash machines carry a 10 year manufacturer's warranty assuring you've invested in superior performance, quality, durability and reliability.

Your local ADC independent authorized distributor



*10 year warranty limited to frame, tub, cylinder and cylinder's shaft, seals, bearings and bearing housing.

EcoWash EWH-60

350 G-Force High Spin Washer-Extractor	
Features	EWH-60
DRUM	
Load Capacity (lb/kg)	60 / 25
Drum Volume (cu. ft./liter)	8.82 / 250
Drum Diameter (in/mm)	30-5/16 / 770
Drum Depth (in/mm)	20-7/8 / 530
DIMENSIONS	
Width (in/mm)	38-1/2 / 977
Depth (in/mm)	38-3/8 / 974
Height (in/mm)	61 / 1549
Weight (lb/Kg)	1,080 / 490
DIMENSIONS WITH PACKAGING	
Crated Width (in/mm)	40-1/4 / 1022
Crated Depth (in/mm)	46-1/2 / 1181
Crated Height (in/mm)	69-3/8 / 1762
Crated Weight (lb/Kg)	1,140 / 517.10
DOOR	
Height to bottom of Door (in/mm)	24 / 609
Door Opening Diameter (in/mm)	14-3/4 / 375
POWER	
Voltage/Phase	208-240 / 3ø
Full load current / Breaker (amps) - 1ø	13 / 20
Full load current / Breaker (amps) - 3ø	9.54 / 15
CONNECTIONS	
Water Inlet (in/mm)	3/4 / 19.05
Steam Inlet (in/mm)	1/2 / 12.7
Drain (in/mm)	3 / 76.2
CYLINDER SPEED	
Washing speed (r.p.m.)	45
Spinning speed (r.p.m.)	900
G-Force	350
FLOOR LOADING	
Static Floor Load	1080 lb / 4,90 kN
Dynamic Floor Load	385 lb / 1,75 kN
Maximum Vertical Load	1466 lb / 6,65 kN
Dynamic Load Frequency (Hz)	15
G Factor	350
OPTION HEAT SOURCES	
Steam Inlet (in/mm)	1/2 / 1.27
Electric	18 kW
WATER	
Average Usage (gallons)*	41.92

* one wash, two rinse cycles



Intuitive Micro Controls (IMC®) That Makes Washing Easy For You and Your Customers

Intuitive Micro Controls (IMC®) is our programmable microprocessor that is customizable, easy to program and easy to use. You can simplify existing programs; modify or delete the temperature and times of each phase of the cycle, as well as modify water levels to achieve maximum savings in your Laundromat. Multi vend pricing capability also enables you to maximize your Laundromat's revenue.

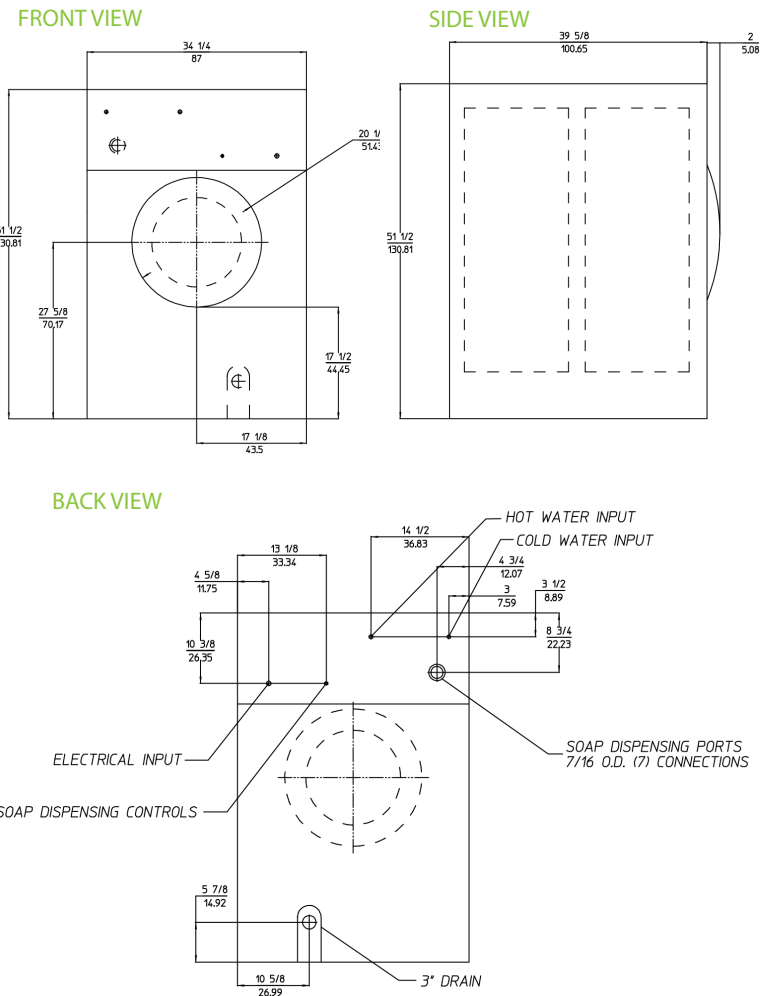

SAVE MORE
Commercial Laundry Equipment

* Specifications are subject to change without notice or obligation. Contact ADC for dimensions not shown or for clarification.

www.Laundryman.com