

40-lb Capacity Soft Mount/350 G-Force Coin Washer/Extractor

Features and Benefits:

- Coin or Card Ready
- Inverter Driven Motor
- Soft Mount
- Stainless Steel Cabinet
- Easy to Program and Easy to Use Controls
- Load Imbalance Detection Before Spinning
- Large, Convenient Supply Dispenser
- Flexible Water Level Settings
- Ergonomic, Easy-Grip Door Handle
- 10 Year Manufacturer's Warranty*

Why Purchase ADC EcoWash?



EWH-40 Coin Washer/Extractor

Soft Mount

EcoWash high spin washer/extractors feature a heavy-duty cast aluminum counter weight and our automatic imbalance detection system. Together these provide maximum stability and gentler movement, prolonging the unit's life.

Durable Door Safety Lock and Handle

The durable ergonomic design of the door handle combined with our Easy Lock™ door lock provides maximum convenience and safety.

Large, Convenient Supply Dispenser

Easy to use, this large supply dispenser allows you to conveniently load your detergent, bleach and fabric softeners before starting your wash cycle.

10 Year Manufacturer's Warranty

ADC's EcoWash machines carry a 10 year manufacturer's warranty assuring you've invested in superior performance, quality, durability and reliability.

Your local ADC independent authorized distributor

EcoWash EWH-40

350 G-Force High Spin Washer-Extractor	
Features	EWH-40
DRUM	
Load Capacity (lb/kg)	40 / 18
Drum Volume (cu. ft./liter)	6.35 / 180
Drum Diameter (in/mm)	27.56 / 700
Drum Depth (in/mm)	18.50 / 470
DIMENSIONS	
Width (in/mm)	34.80 / 884
Depth (in/mm)	33.25 / 844
Height (in/mm)	52.28 / 1404
Weight (lb/Kg)	794 / 360.16
DIMENSIONS WITH PACKAGING	
Crated Width (in/mm)	36.25 / 921
Crated Depth (in/mm)	41 / 1041
Crated Height (in/mm)	65.25 / 1657
Crated Weight (lb/Kg)	844 / 382.83
DOOR	
Height to Bottom of Door (in/mm)	19.75 / 502
Door Opening Diameter (in/mm)	14.75 / 375
POWER	
Voltage/Phase	208-240 / 1, 3ø
Full load current / Breaker (amps) - 1ø	11.56 / 15
Full load current / Breaker (amps) - 3ø	7.53 / 15
CONNECTIONS	
Water Inlet (in/mm)	.75 / 1.90
Drain (in/mm)	3 / 76.2
CYLINDER SPEED	
Washing speed (r.p.m.)	47
Spinning speed (r.p.m.)	950
G-Force	350
FLOOR LOADING	
Static Floor Load	793 lb / 3,60 kN
Dynamic Floor Load	308 lb / 1,40 kN
Maximum Vertical Load	1102 lb / 5 kN
Dynamic Load Frequency (Hz)	16
G Factor	350
OPTION HEAT SOURCES	
Steam Inlet (in/mm)	.50 / 1.27
Electric	12 kW
WATER	
Average Usage (gallons)*	36.24

* one wash, two rinse cycles



Intuitive Micro Controls (IMC®) That Makes Washing Easy For You and Your Customers

Intuitive Micro Controls (IMC®) is our programmable microprocessor that is customizable, easy to program and easy to use. You can simplify existing programs; modify or delete the temperature and times of each phase of the cycle, as well as modify water levels to achieve maximum savings in your Laundromat. Multi vend pricing capability also enables you to maximize your Laundromat's revenue.

FRONT VIEW

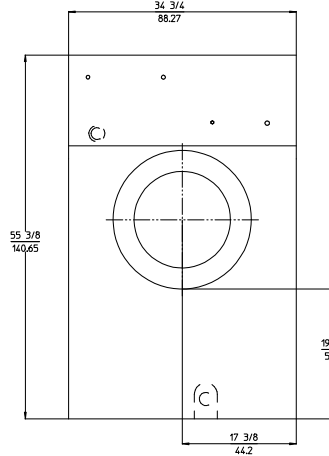

SIDE VIEW

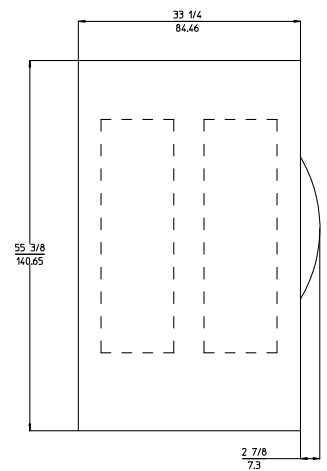

BACK VIEW

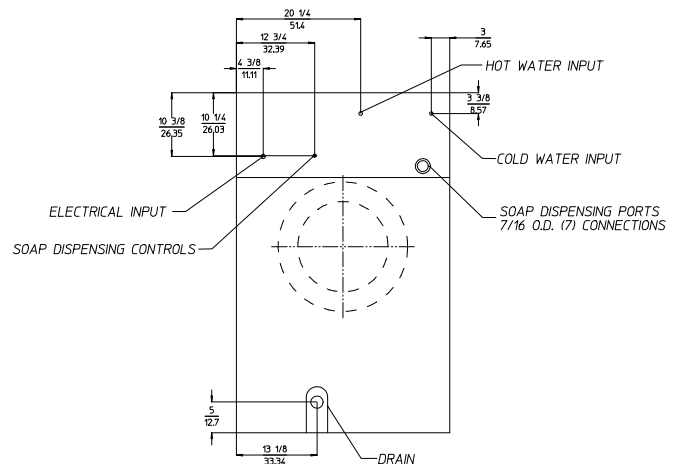

SAVE MORE
Commercial Laundry Equipment

* Specifications are subject to change without notice or obligation. Contact ADC for dimensions not shown or for clarification.

www.Laundryman.com