

## 25-lb Capacity Soft Mount/350 G-Force Coin Washer/Extractor

### Features and Benefits:

- Coin or Card Ready
- Inverter Driven Motor
- Soft Mount
- Stainless Steel Cabinet
- Easy to Program and Easy to Use Controls
- Load Imbalance Detection Before Spinning
- Large, Convenient Supply Dispenser
- Flexible Water Level Settings
- Ergonomic, Easy-Grip Door Handle
- 10 Year Manufacturer's Warranty\*

### Why Purchase ADC EcoWash?



EWH-25 Coin Washer/Extractor

### Soft Mount

EcoWash high spin washer/extractors feature a heavy-duty cast aluminum counter weight and our automatic imbalance detection system. Together these provide maximum stability and gentler movement, prolonging the unit's life.

### Durable Door Safety Lock and Handle

The durable ergonomic design of the door handle combined with our Easy Lock™ door lock provides maximum convenience and safety.

### Large, Convenient Supply Dispenser

Easy to use, this large supply dispenser allows you to conveniently load your detergent, bleach and fabric softeners before starting your wash cycle.

### 10 Year Manufacturer's Warranty

ADC's EcoWash machines carry a 10 year manufacturer's warranty assuring you've invested in superior performance, quality, durability and reliability.

Your local ADC independent authorized distributor



\*10 year warranty limited to frame, tub, cylinder and cylinder's shaft, seals, bearings and bearing housing.

# EcoWash EWH-25

350 G-Force High Spin Washer-Extractor	
Features	EWH-25
<b>DRUM</b>	
Load Capacity (lb/kg)	25 / 10
Drum Volume (cu. ft./liter)	3.53 / 100
Drum Diameter (in/mm)	21 / 533
Drum Depth (in/mm)	16.75 / 425
<b>DIMENSIONS</b>	
Width (in/mm)	27.25 / 692
Depth (in/mm)	31.125 / 790
Height (in/mm)	45.50 / 1155
Weight (lb/Kg)	507 / 229.97
<b>DIMENSIONS WITH PACKAGING</b>	
Crated Width (in/mm)	29.125 / 739
Crated Depth (in/mm)	39.125 / 994
Crated Height (in/mm)	53.75 / 1365
Crated Weight (lb/Kg)	522 / 236.78
<b>DOOR</b>	
Height to Bottom of Door (in/mm)	16.75 / 425
Door Opening Diameter (in/mm)	11.50 / 292
<b>POWER</b>	
Voltage/Phase	208-240 / 1, 3ø
Full load current / Breaker (amps) - 1ø	5.26 / 15
Full load current / Breaker (amps) - 3ø	3.88 / 15
<b>CONNECTIONS</b>	
Water Inlet (in/mm)	.75 / 19.05
Steam Inlet (in/mm)	.50 / 12.7
Drain (in/mm)	3 / 7.62
<b>CYLINDER SPEED</b>	
Washing speed (r.p.m.)	50
Spinning speed (r.p.m.)	1000
G-Force	350
<b>FLOOR LOADING</b>	
Static Floor Load	507 lb / 2,30 kN
Dynamic Floor Load	166 lb / 0,75 kN
Maximum Vertical Load	636 lb / 3,05 kN
Dynamic Load Frequency (Hz)	16,7
G Factor	300
<b>OPTIONAL HEAT SOURCES</b>	
Steam Inlet (in/mm)	.50 / 1.27
Electric	6 kW
<b>WATER</b>	
Average Usage (gallons)*	24.56

\* one wash, two rinse cycles



## Intuitive Micro Controls (IMC®) That Makes Washing Easy For You and Your Customers

Intuitive Micro Controls (IMC®) is our programmable microprocessor that is customizable, easy to program and easy to use. You can simplify existing programs; modify or delete the temperature and times of each phase of the cycle, as well as modify water levels to achieve maximum savings in your Laundromat. Multi vend pricing capability also enables you to maximize your Laundromat's revenue.

FRONT VIEW

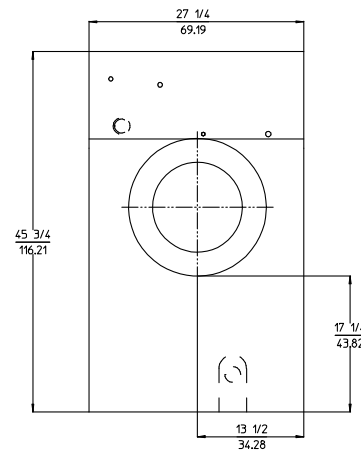

SIDE VIEW

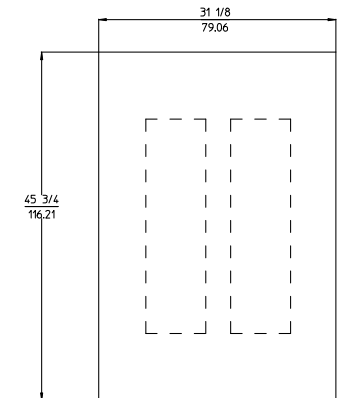

BACK VIEW

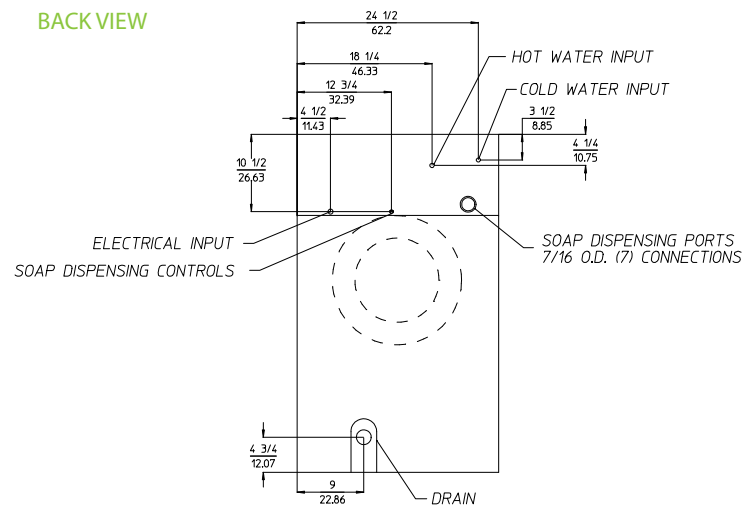

**SAVE MORE**  
Commercial Laundry Equipment

\* Specifications are subject to change without notice or obligation. Contact ADC for dimensions not shown or for clarification.

www.Laundryman.com