

30-lb Capacity Rigid Mount/200 G-Force Coin Washer/Extractor

Features and Benefits:

- Coin or Card Ready
- Inverter Driven Motor
- Heavy-Duty Structural Tube Construction
- Stainless Steel Cabinet
- Easy to Program and Easy to Use Controls
- Load Imbalance Detection Before Spinning
- Large, Convenient Supply Dispenser
- Flexible Water Level Settings
- Ergonomic, Easy-Grip Door Handle
- 10 Year Manufacturer's Warranty*

Why Purchase ADC EcoWash?



EWR-30 Coin Washer/Extractor

Rugged Structural Tube Construction

EcoWash rapid spin washer/extractors are constructed with a structural tube design frame in combination with a heavy-duty cast aluminum counter weight to provide superior strength and maximum stability throughout the wash cycle.

Durable Door Safety Lock and Handle

The durable ergonomic design of the door handle combined with our Easy Lock™ door lock provides maximum convenience and safety.

Large, Convenient Supply Dispenser

Easy to use, this large supply dispenser allows you to conveniently load your detergent, bleach and fabric softeners before starting your wash cycle.

10 Year Manufacturer's Warranty

ADC's EcoWash machines carry a 10 year manufacturer's warranty assuring you've invested in superior performance, quality, durability and reliability.

Your local ADC independent authorized distributor



*10 year warranty limited to frame, tub, cylinder and cylinder's shaft, seals, bearings and bearing housing.

EcoWash EWR-30

200 G-Force Rapid Spin Washer-Extractor	
Features	EWR-30
DRUM	
Load Capacity (lb/kg)	30 / 13
Drum Volume (cu. ft./liter)	4.6 / 130
Drum Diameter (in/mm)	24-1/2 / 622
Drum Depth (in/mm)	17 / 432
DIMENSIONS	
Width (in/mm)	31-1/8 / 791
Depth (in/mm)	34-1/4 / 861
Height (in/mm)	51-3/16 / 1300
Weight (lb/Kg)	486 / 225
DIMENSIONS WITH PACKAGING	
Crated Width (in/mm)	32-1/2 / 826
Crated Depth (in/mm)	39 / 991
Crated Height (in/mm)	60-1/4 / 1530
Crated Weight (lb/Kg)	536 lb / 243
DOOR	
Height to Bottom of Door (in/mm)	16-3/4 / 425
Door Opening Diameter (in/mm)	14-3/4 / 375
POWER	
Voltage/Phase	208-240 / 1, 3ø
Full load current / Breaker (amps) - 1ø	6.35 / 15
Full load current / Breaker (amps) - 3ø	4.51 / 15
CONNECTIONS	
Water Inlet (in/mm)	3/4 / 19.05
Steam Inlet (in/mm)	1/2 / 12.7
Drain (in/mm)	3 / 76.2
CYLINDER SPEED	
Washing speed (r.p.m.)	50
Spinning speed (r.p.m.)	760
G-Force	200
FLOOR LOADING	
Static Floor Load	506 lb / 2,25 kN
Dynamic Floor Load	135 lb / 0,6 kN
Maximum Vertical Load	641 lb / 2,85 kN
Dynamic Load Frequency (Hz)	12.2
G Factor	200
OPTION HEAT SOURCES	
Steam Inlet (in/mm)	1/2 / 1.27
Electric	9 kW
WATER	
Average Usage (gallons)*	27.52

*one wash, two rinse cycles

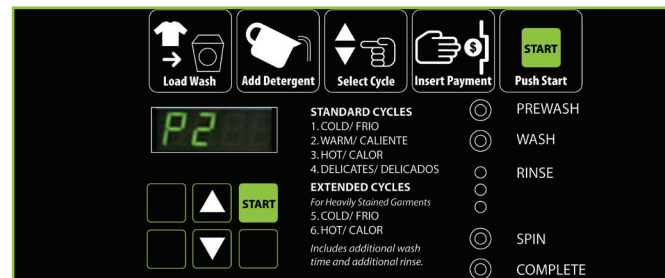

Intuitive Micro Controls (IMC®) That Makes Washing Easy For You and Your Customers

Intuitive Micro Controls (IMC®) is our programmable microprocessor that is customizable, easy to program and easy to use. You can simplify existing programs; modify or delete the temperature and times of each phase of the cycle, as well as modify water levels to achieve maximum savings in your Laundromat. Multi vend pricing capability also enables you to maximize your Laundromat's revenue.

FRONT VIEW

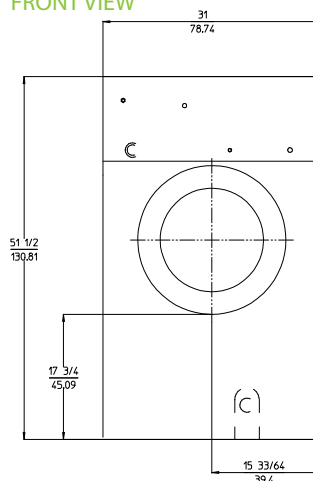

SIDE VIEW

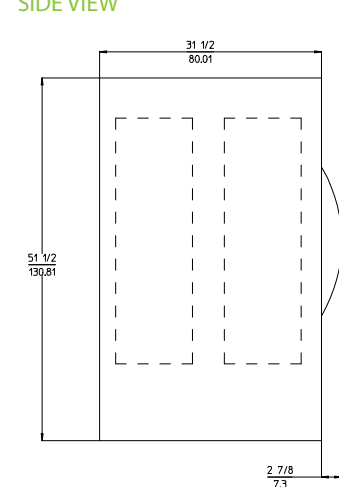

BACK VIEW

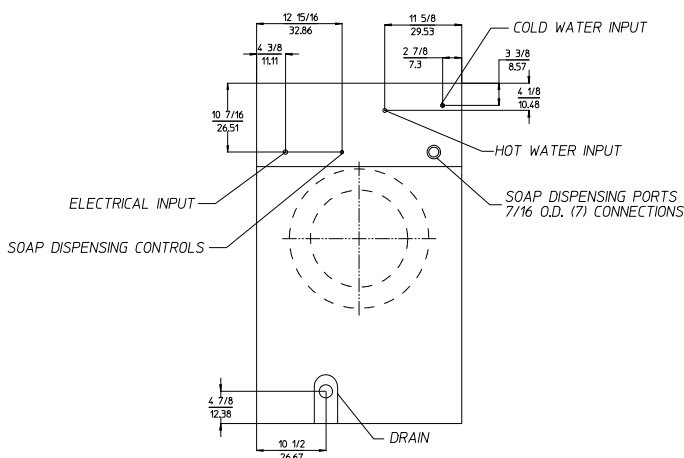

* Specifications are subject to change without notice or obligation. Contact ADC for dimensions not shown or for clarification.